

Equipment Data Sheet

Model:	ESD-100
Frame Style:	Extruded aluminum frame with painted vanity panels
Description:	Designed to drop down a bare board from the stack of the bare boards.

Standard Features:

- PCB Size: 50 x 50 – 530 x 460
- Programmable Logic Controller
- Hand crank width adjusting
- Able to link with the magazine loader
- PCB drop down type
- Thickness : 1.6mm Load up to 80 pcs
- Left to right travel, front rail fixed
- Conforms to SMEMA Spec. 1.2

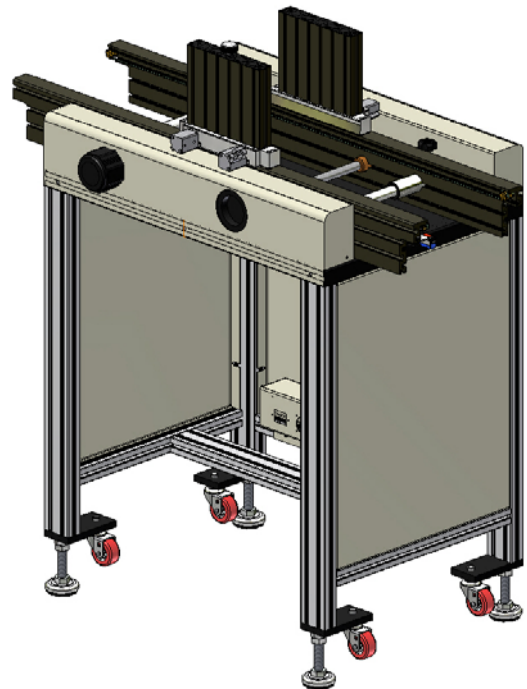

Options:

- ESD grounding receptacles
- Touch screen of the operation panel
- Auto or Semi-auto width adjust
- Speed control

Facilities Requirements:

Electrical:	AC220V 50-60Hz 1 Phase
Conveyor height	900mm+/-30mm / 950mm+/-30mm
Air:	5 kgf/cm ²
Power consumption	Max. 200W, 1A